

JUKI®

No. 0005-02

1987.5

BE806NTPJA

model **MO-800**

サブクラス
SUBCLASSES

二本針オーバーロックマシン

Two-needle overlock machine

PARTS BOOK

MO-806

MO-807

MO-808

MO-809

MO-812

MO-814

MO-821

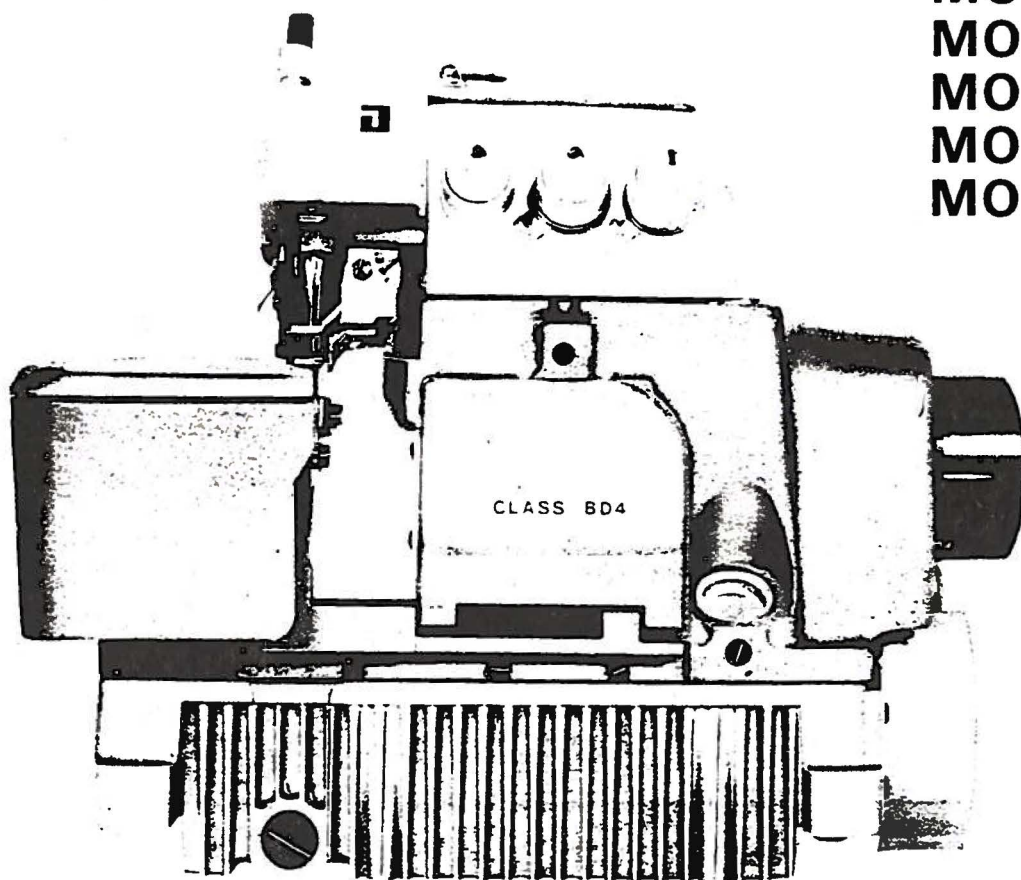

TOKYO JUKI INDUSTRIAL CO., LTD.

From the library of: Superior Sewing Machine & Supply LLC

HOW TO MAKE USE OF THIS PARTS BOOK

- As a basic principle, this parts book is divided into various sections according to the functions of respective parts.
- The part numbers of parts shown in the figure indicate the corresponding numbers(Ref.No.) shown by the Index.
- Explanation of codes

- 1 mark means this part is changed from the previous parts book.
- 01 refer to "Note" explanation at bottom of page.

2) Codes on the "E.C. (Ex. - Obsolete/Added)" column

- A. 10/74 Added from October, 1974
- D. 1/75 Obsolete from January, 1975
- When D is preceded and A is added and imbedded together
D. 12/74
A. 12/74

- ① When previous parts (Obsolete part) and new parts (Added parts) are not interchangeable with each other:
In this case, even obsolete parts (D.) can be ordered with the obsolete part number, so select the parts with changed dates and place your orders.

(Example)

Ref. No.	Note	Part No.	Description	E.C. 変更年月	品名	Amt. Req. 数量
1		B1401-100-000	Needle bar	D. 12/74	ハリホー	1
1-1		B1401-100-000-A	Needle bar	A. 12/74	ハリホー	1

- ② In case when previous parts and new part are interchangeable with each other:
In this case the new part number is replaced on the "品名 (Japanese)" column of the previous parts, so please order by the new part number!

(Example)

Ref. No.	Note	Part No.	Description	E.C. 変更年月	品名	Amt. Req. 数量
1		B1105-200-000	Frame cover	D. 12/74	B1105-300-000	—
		B1105-300-000	Frame cover	A. 12/74	フレームカバー	1

- 4 C.3/75 This indicates error was discovered in March, 1975 and so it was corrected to a new part number.
Please note that in this case, the corrected part number is shown in the part number column and the wrong part number is shown in the "品名 (Japanese)" column, so please order by the correct part number.

(Example)

Ref. No.	Note	Part No.	Description	E.C. 変更年月	品名	Amt. Req. 数量
1	*	B1105-500-000	Frame cover	C.3/75	B1105-600-000	1
		↑ Correct No.			↑ Wrong No.	

- 5 M.5/75 The amount required is changed from March, 1975
The new amount required is shown in the "Amt. Req." column.

3) Codes on the "Amt. Req." column

- 2 Indicates amount required is 2.
- 2.0 Indicates length in meters. (unit is meter)
- Indicates parts obsoleted from the parts book.
- (1) Indicates sub parts which construct the assembly part.
Assembly part is shown as "asm." and クミ in Japanese, in the "Description" column.

(Example)

Ref. No.	Note	Part No.	Description	E.C. 変更年月	品名	Amt. Req. 数量
10		B1105-900-0A0	Frame cover ^{asm.}		フレームカバー ^{クミ}	1
11		B1105-900-000	Frame cover		フレームカバー	(1)
12		SS-8110310-SP	Screw 11/64-40 L=2.8		トメネジ 11/64-40 L=2.8	(2)

When Ordering The Spare Parts:

In order to ensure that we deliver the correct parts to you, please clearly state when ordering the corresponding PART NUMBER (e.g. B1109-012-A00) and also the PARTS BOOK NUMBER (e.g. 0010-01, given at the top right of the cover) or the MACHINE SERIAL NUMBER, because there are some parts which have been changed.

パーツブックの見方

- このパーツブックは、原則として、機械別に分類された各項目からなっております。
- 図に示された部品の品番は、図に示されている No. (Part No.) に対応するインデックスによって、その品番がわかります。
- 記号の説明

1) "注記" 欄の記号

- ① 変更印……………前回のパーツブックと比較して今回変更された部品を意味します。
- ② 01……………ページ下の"注記"の説明を参照して下さい。

2) "変更年月" 欄の記号

- ① A. 10/74……………1974年10月より追加された。
- ② D. 1/75……………1975年1月より削除された。
- ③ D. (削除)、A. (追加) が連記してある場合。

D. 12/74
A. 12/74

④ 部品の互換性がない変更の場合

この場合は削除 (D) された品番でも御注文できますから、変更年月により、いずれかの部品を選択して御注文下さい。

[例]

Ref. No.	Note	Part No.	Description	E.C.	品名	Amt. Req. 数量
	注記	品番		変更年月		
1	※	B1401-100-000	Needle bar	D.12/74	ハリボー	—
1-1	※	B1401-100-000-A	Needle bar	A.12/74	ハリボー	1

⑤ 部品の互換性がある場合の変更

この場合は、旧部品の和文品名欄にそれにかわる新しい品番が記入してありますので、新しい品番で御注文下さい。

[例]

Ref. No.	Note	Part No.	Description	E.C.	品名	Amt. Req. 数量
	注記	品番		変更年月		
1	※	B1105-200-000	Frame cover	D.12/74	B1105-300-000	—
	※	B1105-300-000	Frame cover	A.12/74	フレームカバー	1

④ C. 3/75……………1975年3月に品番のミスが判明したため、正しい品番に訂正された。

この場合は品番欄に正しい品番を、和文品名欄に間違いの品番が記入してありますので、正しい品番で御注文下さい。

[例]

Ref. No.	Note	Part No.	Description	E.C.	品名	Amt. Req. 数量
	注記	品番		変更年月		
1	※	B1105-500-000	Frame cover	C.3/75	B1105-600-000	1
		↑	正しい品番		↑	間違っていた品番

⑤ M. 5/75……………1975年5月より数量が変更になった。

この場合数量欄には新しい数量が表示してあります。

3) "数量" 欄の記号

- ① 2……………数量、2個を表わします。
- ② 2.0……………長さ、2メートルを表わします。(単位はメートルです)
- ③ —……………このパーツブックから削除された部品です。
- ④ (1)……………組部品を構成している子部品を表わします。

組部品は品名欄に英文で "asm." と和文で "クミ" と表示してあります。

[例]

Ref. No.	Note	Part No.	Description	E.C.	品名	Amt. Req. 数量
	注記	品番		変更年月		
10		B1105-900-0A0	Frame cover asm.		フレームカバー クミ	1
11		B1105-900-000	Frame cover		フレームカバー	(1)
12		SS-8110310-SP	Screw 11/64-40 L=2.8		トメネジ 11/64-40 L=2.8	(2)

補用部品注文の際の御注意

このパーツブックに記載されている補用部品を御注文の際は、部品の番号(例えば、B1109-012-A00)で御注文下さい。合わせて、御覧のパーツブックの管理番号(表紙右上、例えば、No. 0010-01)又は、機械番号を御連絡頂ければ幸いです。

改良のため部品の一部が変更になる場合がありますのでご了承下さい。

CONTENTS

目次

1	MO-814-ZA5	1
2	MO-814-XA5	1
3	MO-814-XB5	2
4	MO-814-AA4	2
5	MO-814-AC4	3
6	MO-814-AD4	3
7	MO-814-BC4	4
8	MO-814-BE4	4
9	MO-814-CD4	4
10	MO-814-BD6	5
11	MO-814-CD6	5
12	MO-812-CE6	6
13	MO-812-CF6	6
14	MO-812-DD6	7
15	MO-812-DF6	7
16	MO-806	8
17	MO-807	8
18	MO-808	9
19	MO-809	9
20	MO-812	10
21	MO-821	10
22	NUMERICAL INDEX 索引	11

Other parts books related to this model :

この機種に関連するパーツブックとして下記のパーツブックがあります。

1. MO-800 Standard model (No. 0008) (No. 0063)
MO-800 標準機種
2. MO-800 Subclass Single-needle overlock machine (No. 0004)
MO-800 サブクラス 一本針オーバロックマシン
3. MO-800 Subclass Safety stitch sewing machine (No. 0006)
MO-800 サブクラス インターロックマシン

MO-814

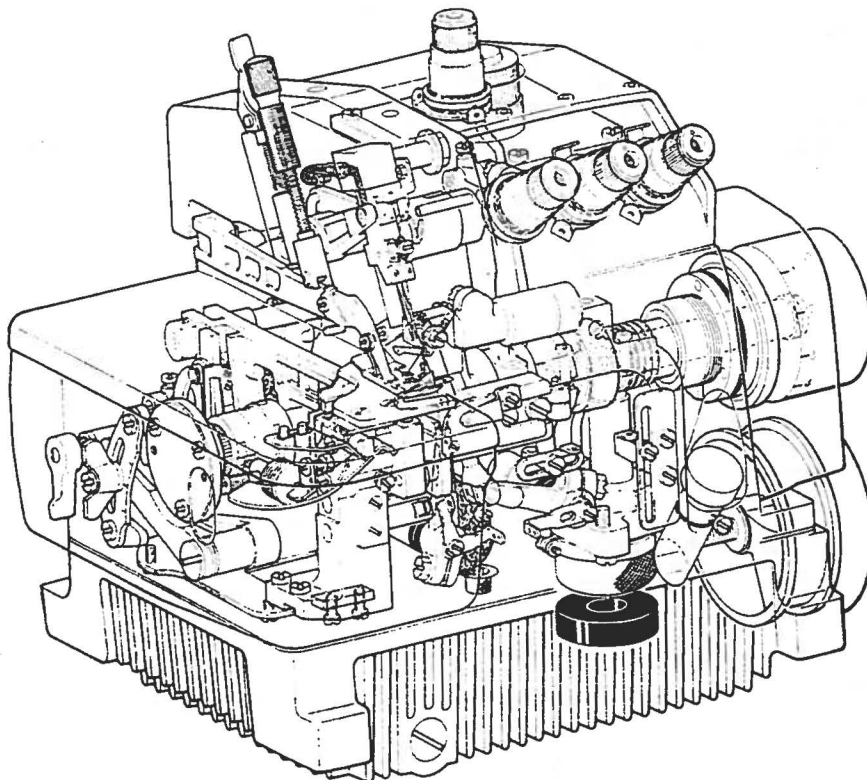

MO-814-ZA5

MO-814-XA5

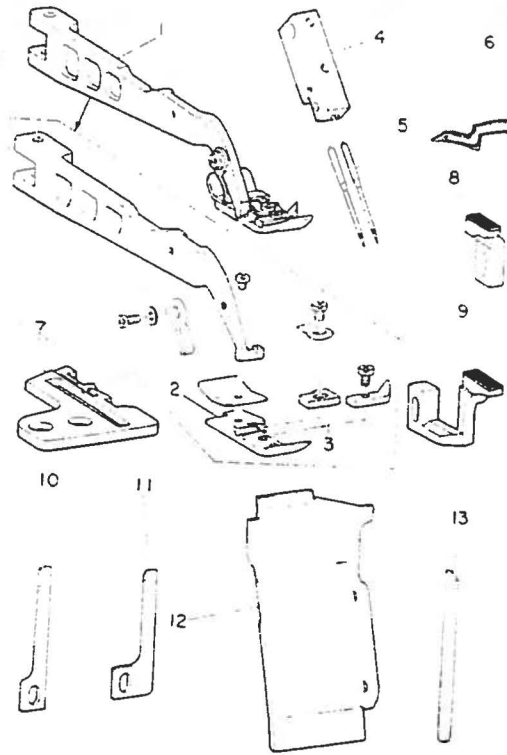
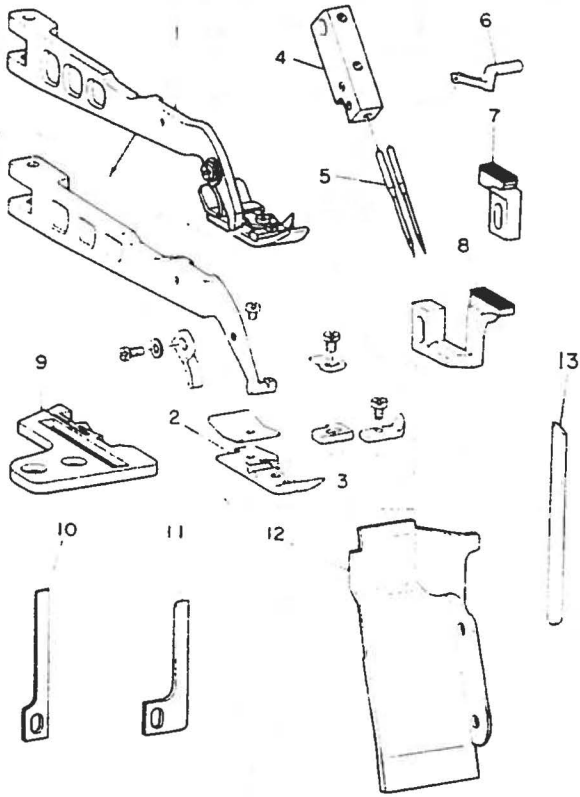

MO-814-ZA5

Ref. No.	Note	Part No.	Description	E.C.	Amt. Req.
	注記	品番		変更年月	数量
1		B1507-814-0AF	Presser foot asm.	押エ結合	1
2		B1507-814-00C	Presser foot	押エ	(1)
3		B1509-814-00D	Stitch tongue	糸スベリ台	(1)
4		B1419-814-ZAE	Needle clamp (with needle stopper)	針留組合 (針ストップ付)	1
5		MDC-C46B0900	Needle DC x C46 =9	針DC・C46 =9	2
6		B2519-804-000	Upper looper	上ルーバー	1
7		B1656-804-00D	Main feed dog	主送り歯	1
8		B1657-804-00E	Differential feed dog	副送り歯	1
9		R4102-E0A-L00	Throat plate	針板	1
10		B4121-814-Z0A	Needle guard (A)	針受 (A)	1
11		B4120-814-Z0A	Needle guard (B)	針受 (B)	1
12		B1121-704-000	Chip guard cover	布クスカバー	1
13		B4118-804-000	Lower knife	下メス	1

MO-814-XA5

1		B1507-814-0AF	Presser foot asm.	押エ結合	1
2		B1507-814-00C	Presser foot	押エ	(1)
3		B1509-814-00D	Stitch tongue	糸スベリ台	(1)
4		B1419-814-XAD	Needle clamp (with needle stopper)	針留 (針ストップ付)	1
5		MDC-C47B0900	Needle DC x C47 =9	針DC・C47 =9	2
6		B2519-804-000	Upper looper	上ルーバー	1
7		R4103-E0A-P00	Throat plate	針板	1
8		B1657-804-00E	Differential feed dog	副送り歯	1
9		B1656-804-00D	Main feed dog	主送り歯	1
10		B4121-814-Z0A	Needle guard (A)	針受 (A)	1
11		B4120-814-Z0A	Needle guard (B)	針受 (B)	1
12		B1121-704-000	Chip guard cover	布クスカバー	1
13		B4118-804-000	Lower knife	下メス	1

All parts not mentioned above are same as those of Model MO-814-BD4. 上記以外の部品はMO-814-BD4と共通です。

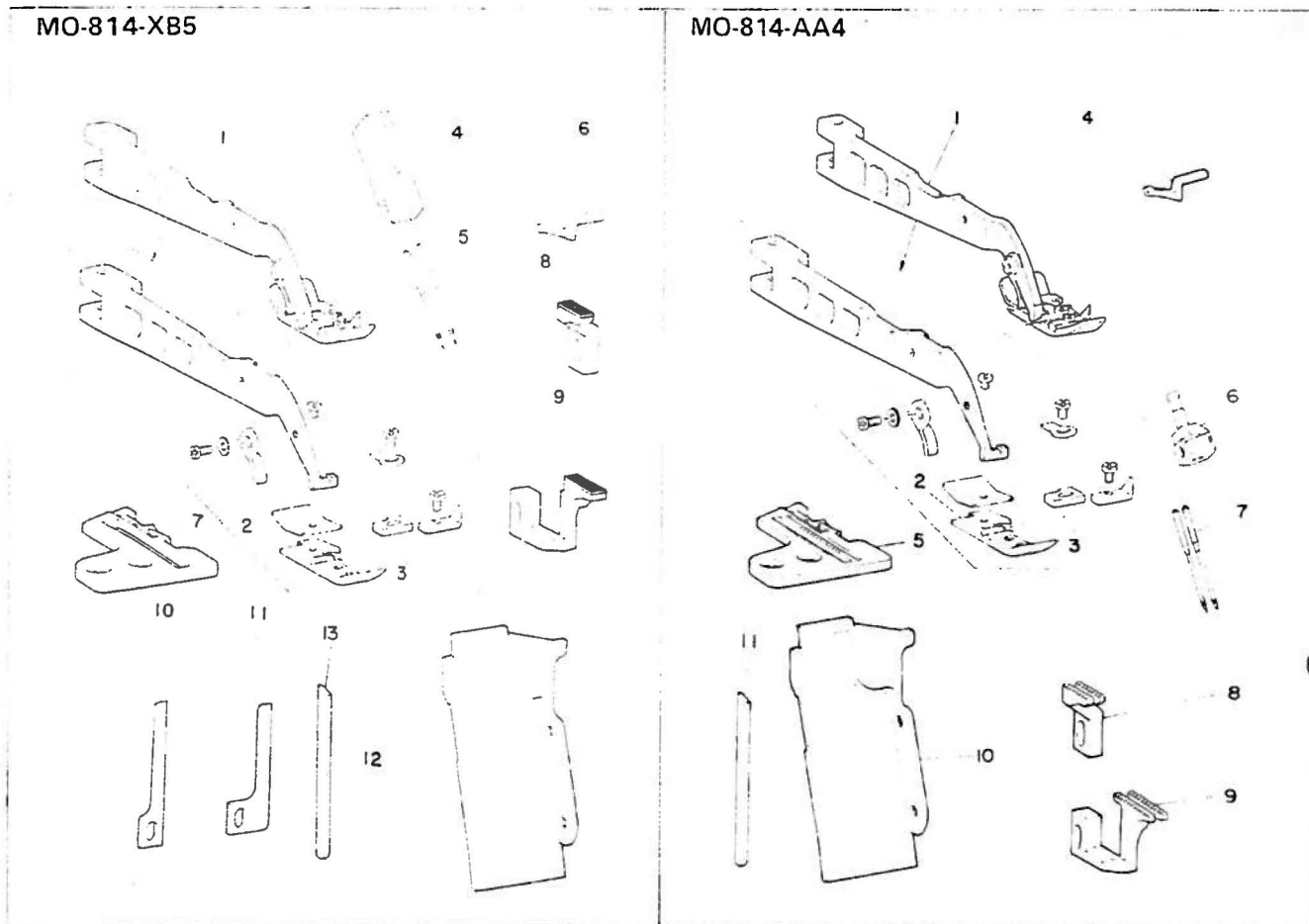

3. MO-814-XB5

Ref. No.	Note	Part No.	Description	E.C.	Amt. Rec.
1	注記	B1507-814-0AC	Presser foot asm.	変更年月	1
2		B1507-814-00C	Presser foot		(1)
3		B1509-814-00B	Stitch tongue		(1)
4		B1419-814-XAD	Needle clamp (with needle stopper)		1
5		MDC-C47B0900	Needle DC x C47 =9		2
6		B2519-804-000	Upper looper		1
7		R4103-E0B-P00	Throat plate		1
8		B1656-804-00D	Main feed dog		1
9		B1657-804-00E	Differential feed dog		1
10		B4121-814-Z0A	Needle guard (A)		1
11		B4120-814-Z0A	Needle guard (B)		1
12		B1121-704-000	Chip guard cover		1
13		B4118-804-000	Lower knife		1

4. MO-814-AA4

1		B1507-814-0AF	Presser foot asm.	押エ結合	1
2		B1507-814-00C	Presser foot	押エ	(1)
3		B1509-814-00D	Stitch tongue	糸スベリ台	(1)
4		B2519-804-000	Upper looper	上ルーバー	1
5		R4204-E0A-B00	Throat plate	針板	1
6		B1420-714-A00	Double needle needle clamp	二本針針留	1
7		MDC-C46B0900	Needle DC x 3 =9	針DC x 3 =9	2
8		B1656-805-000	Main feed dog	主送り歯	1
9		B1657-805-000-A	Differential feed dog	副送り歯	1
10		B1121-704-000	Chip guard cover	ホクスカバー	1
11		B4118-804-000	Lower knife	下メス	1

• All parts not mentioned above are same as those of Model MO-814-BD4. 上記以外の部品はMO-814-BD4と共通です。

MO-814-AC4

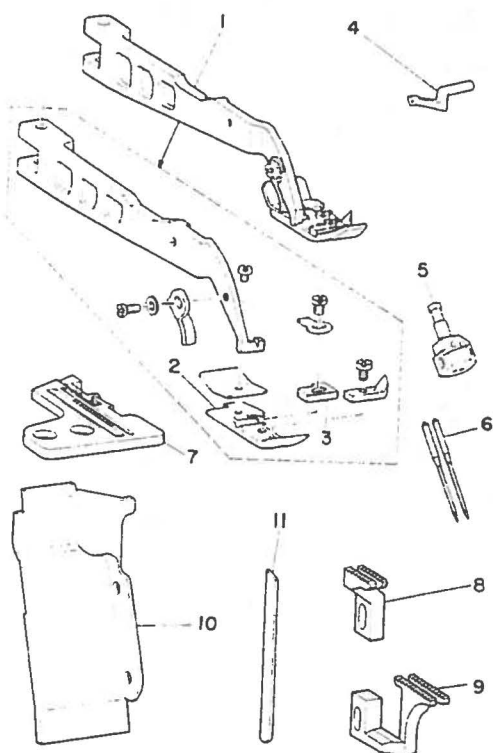

MO-814-AD4

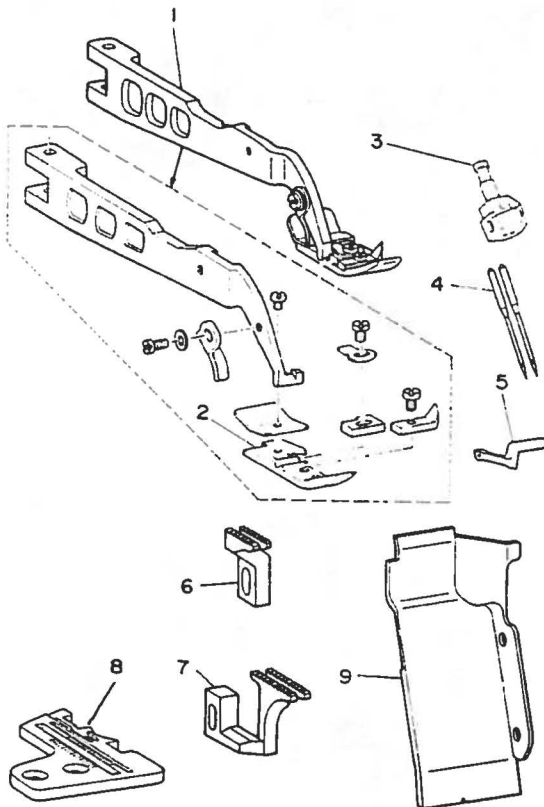

MO-814-AC4

Note	Part No.	Description	E.C.	Amt. Req.
注記	品番		変更年月	数量
	B1507-814-0AC	Presser foot asm.	押エ結合	1
	B1507-814-00C	Presser foot	押エ	(1)
	B1509-814-00B	Stitch tongue	糸スベリ台	(1)
	B2519-804-000	Upper looper	上ルーバー	1
	B1420-714-A00	Double needle needle clamp	二本針針留	1
	MDC-C46B0900	Needle DC x 3 #9	針DC×3 #9	2
	R4204-E0C-B00	Throat plate	針板	1
	B1656-805-000	Main feed dog	主送り歯	1
	B1657-805-000-A	Differential feed dog	副送り歯	1
	B1121-704-000	Chip guard cover	布クスカバー	1
	B4118-804-000	Lower knife	下メス	1

MO-814-AD4

B1507-814-0AE	Presser foot asm.	押エ結合	1
B1509-814-00C	Stitch tongue	糸スベリ台	(1)
B1420-714-A00	Double needle needle clamp	二本針針留	1
MDC-C46B0900	Needle DC x 3 #9	針DC×3 #9	2
B2519-804-000	Upper looper	上ルーバー	1
B1656-805-000	Main feed dog	主送り歯	1
B1657-805-000-A	Differential feed dog	副送り歯	1
R4204-E0D-B00	Throat plate	針板	1
B1121-704-000	Chip guard cover	布クスカバー	1

All parts not mentioned above are same as those of Model MO-814-BD4. 上記以外の部品はMO-814-BD4と共通です。

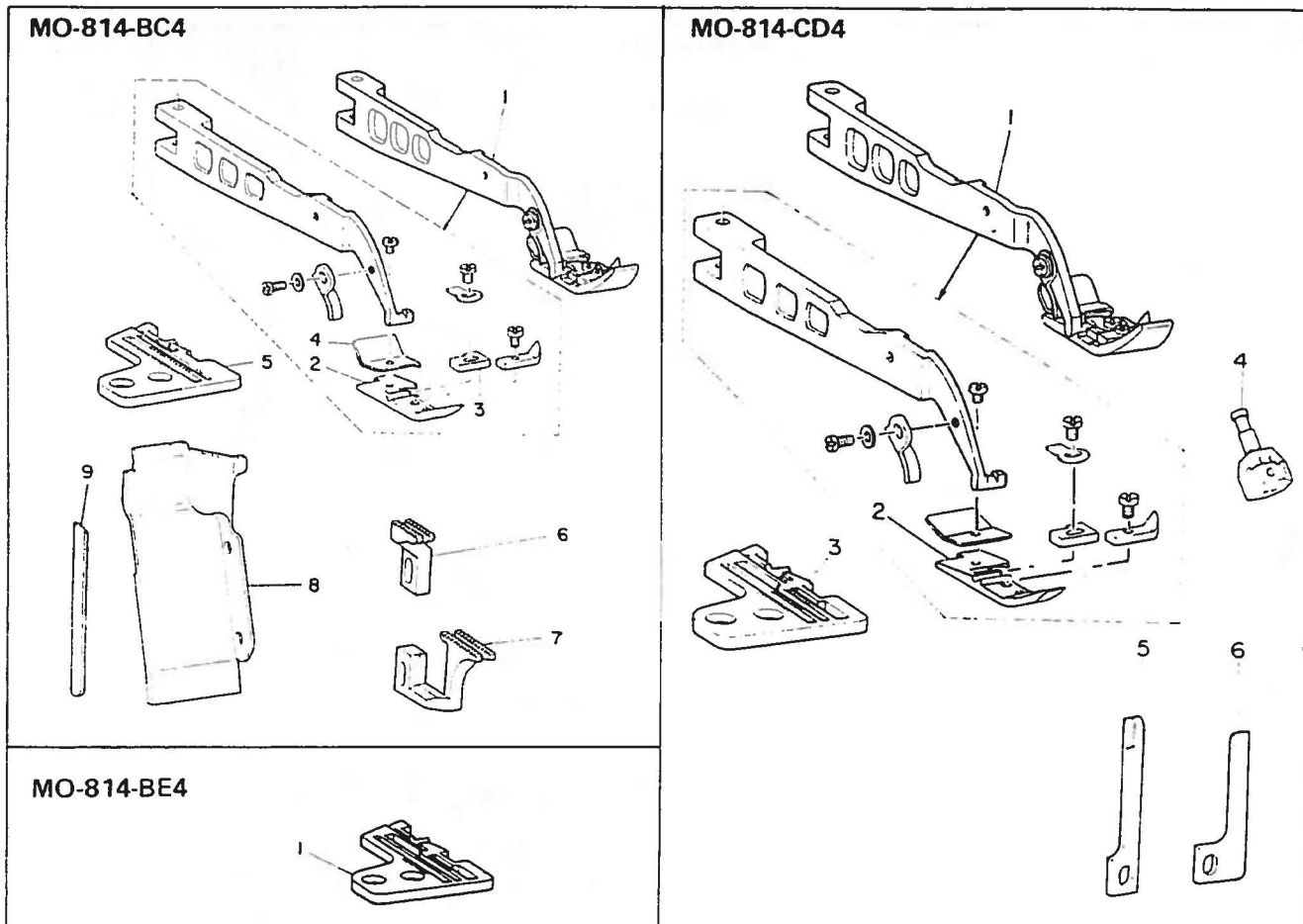

7. MO-814-BC4

Ref. No.	Note	Part No.	Description	E.C.	Amt. Req.
1	注記	B1507-814-0AC	Presser foot asm.	変更年月	数量
2		B1507-814-00C	Presser foot	押エ結合	1
3		B1509-814-00B	Stitch tongue	押エ	(1)
4		B1511-804-000	Curl guard	糸スベリ台	(1)
5		R4205-E0C-C00	Throat plate	空環止メ	(1)
6		B1656-805-000	Main feed dog	針板	1
7		B1657-805-000-A	Differential feed dog	主送り歯	1
8		B1121-704-000	Chip guard cover	副送り歯	1
9		B4118-804-000	Lower knife	布クズカバー	1
				下メス	1

8. MO-814-BE4

1		R4305-E0D-E00	Throat plate	針板	1
---	--	---------------	--------------------	----------	---

9. MO-814-CD4

1		B1507-814-CAA	Presser foot asm.	押エ結合	1
2		B1507-814-C0A	Presser foot	押エ	(1)
3		R4206-E0D-E00	Throat plate	針板	1
4		B1420-714-C00	Double needle needle clamp	二本針針留	1
5		B4121-814-C0A	Needle guard (A)	針受 (A)	1
6		B4120-814-C0A	Needle guard (B)	針受 (B)	1

* All parts not mentioned above are same as those of Model MO-814-BD4. 上記以外の部品はMO-814-BD4と共通です。

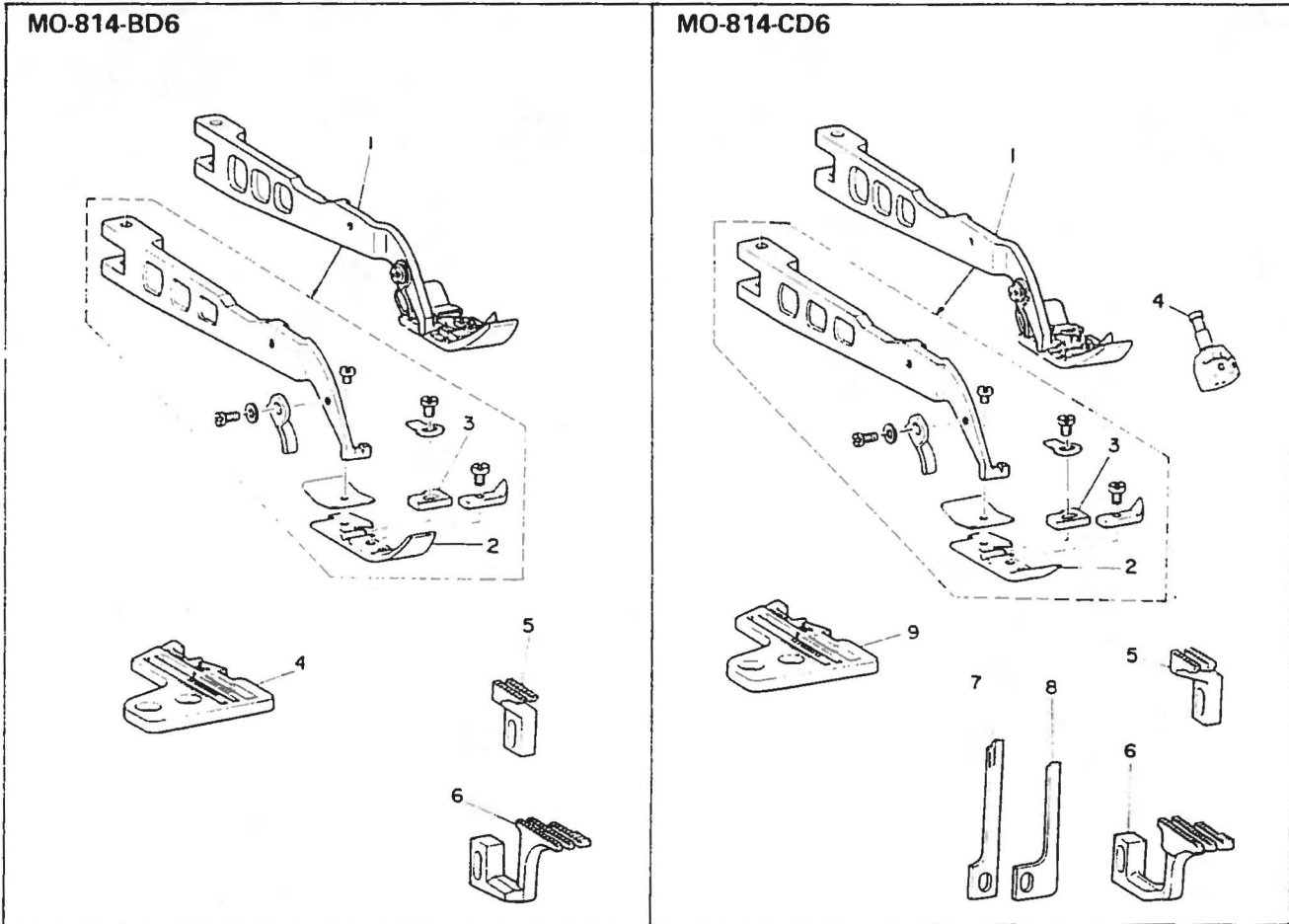

10. MO-814-BD6

Ref. No.	Note	Part No.	Description	E.C.	Amt. Req.
	注記	品番		変更年月	数量
1		B1507-814-0AD	Presser foot asm.	押エ結合	1
2		B1507-814-00D	Presser foot	押エ	(1)
3		B1509-814-00C	Stitch tongue	糸スベリ台	(1)
4		R4305-E0D-E00	Throat plate	針板	1
5		B1656-814-B0A	Main feed dog	主送り歯	1
6		B1657-814-B0A	Differential feed dog	副送り歯	1

11. MO-814-CD6

1		B1507-814-0AD	Presser foot asm.	押エ結合	1
2		B1507-814-00D	Presser foot	押エ	(1)
3		B1509-814-00C	Stitch tongue	糸スベリ台	(1)
4		B1420-714-C00	Double needle clamp	二本針針留	1
5		B1656-814-B0A	Main feed dog	主送り歯	1
6		B1657-814-B0A	Differential feed dog	副送り歯	1
7		B4120-814-C0A	Needle guard (B)	針受 (B)	1
8		B4121-814-C0A	Needle guard (A)	針受 (A)	1
9		R4306-E0D-E00	Throat plate	針板	1

* All parts not mentioned above are same as those of Model MO-814-BD4 上記以外の部品はMO-814-BD4と共通です。

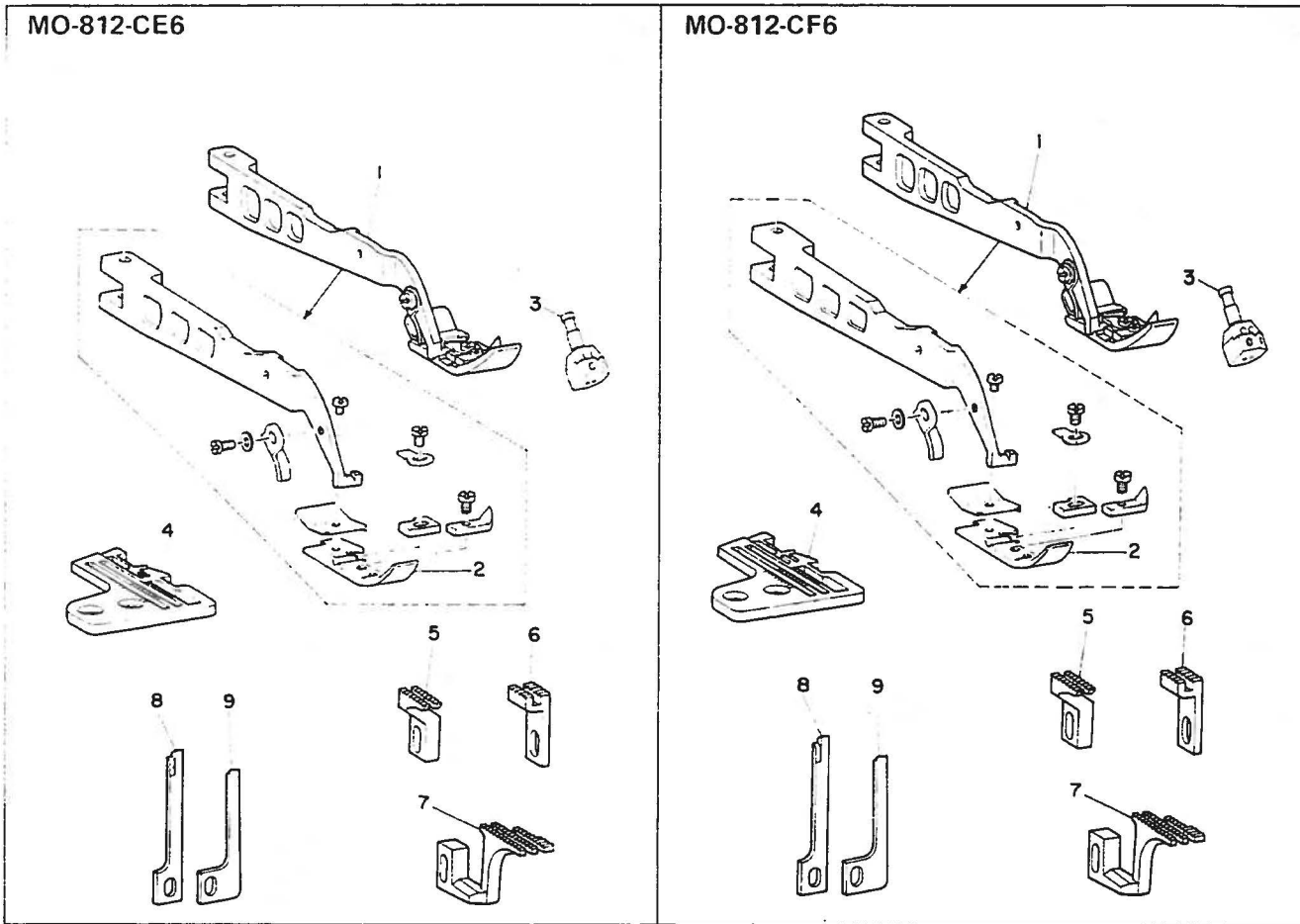

12. MO-812-CE6

Ref. No.	Note	Part No.	Description
	注記	品番	
1		B1507-814-BAG	Presser foot asm.
2		B1507-814-00G	Presser foot
3		B1420-712-C0B	Double needle needle clamp
4		R4306-E0E-E00	Throat plate
5		B1656-812-D0C	Main feed dog
6		B1658-812-00A	Auxiliary feed dog
7		B1657-812-D0A	Differential feed dog
8		B4121-814-C0A	Needle guard (A)
9		B4120-814-C0A	Needle guard (B)

E.C.	品名	Amt. Req.
変更年月		数量
	押エ結合	1
	押エ	(1)
	二本針針留	1
	針板	1
	主送り歯	1
	補助送り歯	1
	副送り歯	1
	針受 (A)	1
	針受 (B)	1

13. MO-812-CF6

1		B1507-814-BAG	Presser foot asm.
2		B1507-814-00G	Presser foot
3		B1420-712-C0B	Double needle needle clamp
4		R4306-E0F-E00	Throat plate
5		B1656-812-D0C	Main feed dog
6		B1658-812-00A	Auxiliary feed dog
7		B1657-812-D0A	Differential feed dog
8		B4121-814-C0A	Needle guard (A)
9		B4120-814-C0A	Needle guard (B)

	押エ結合	1
	押エ	(1)
	二本針針留	1
	針板	1
	主送り歯	1
	補助送り歯	1
	副送り歯	1
	針受 (A)	1
	針受 (B)	1

* All parts not mentioned above are same as those of Model MO-814-BD4. 上記以外の部品はMO-814-BD4と共通です。

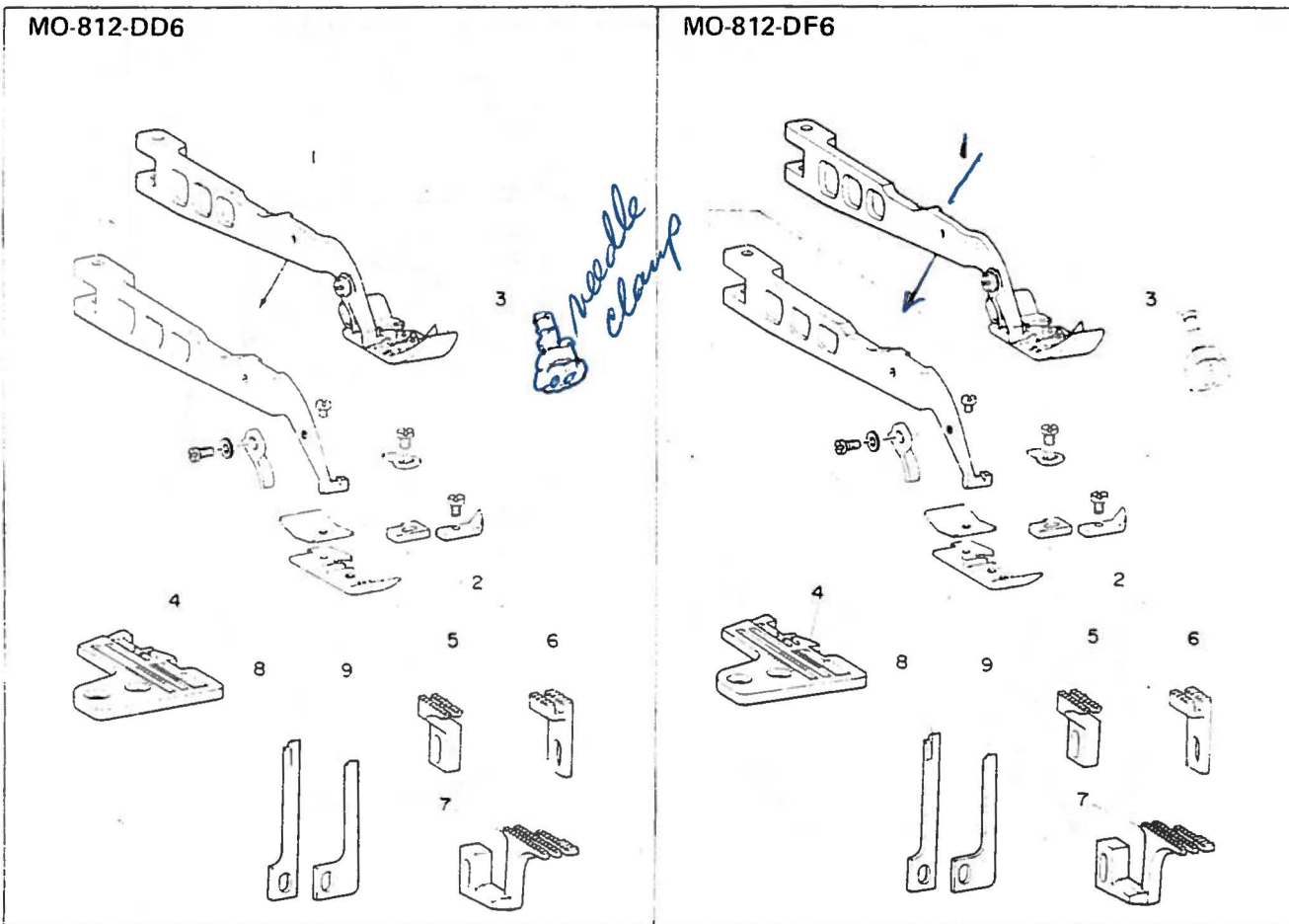

Needle DCX27 3660/00-14

14. MO-812-DD6

Ref. No.	Note	Part No.	Description	E.C.	Amt. Req.
	注記	品番		変更年月	数量
1		B1507-812-DAC	Presser foot asm.	押工結合	1
2		B1507-812-D0C	Presser foot	押工	(1)
3		B1420-712-D00	Double needle needle clamp	二本針針留	1
4		R4308-ECD-E00	Throat plate	針板	1
5		B1656-812-D0C	Main feed dog	主送り歯	1
6		B1658-812-00A	Auxiliary feed dog	補助送り歯	1
7		B1657-812-D0A	Differential feed dog	副送り歯	1
8		B4121-812-00J	Needle guard (J)	針受 (J)	1
9		B4120-812-00H	Needle guard (H)	針受 (H)	1

15. MO-812-DF6

1		B1507-812-DAC	Presser foot asm.	押工結合	1
2		B1507-812-D0C	Presser foot	押工	(1)
3		B1420-712-D00	Double needle needle clamp	二本針針留	1
4		R4308-E0F-E00	Throat plate	針板	1
5		B1656-812-D0C	Main feed dog	主送り歯	1
6		B1658-812-00A	Auxiliary feed dog	補助送り歯	1
7		B1657-812-D0A	Differential feed dog	副送り歯	1
8		B4121-812-00J	Needle guard (J)	針受 (J)	1
9		B4120-812-00H	Needle guard (H)	針受 (H)	1

* All parts not mentioned above are same as those of Model MO-814-BD4. 上記以外の部品はMO-814-BD4と共通です。

MO-806

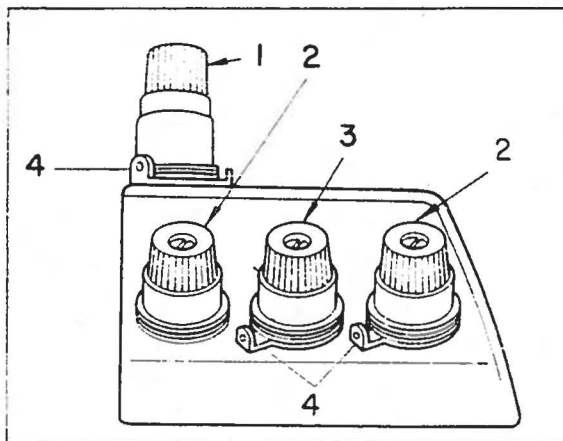
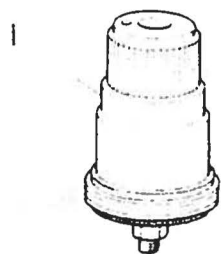

MO-807

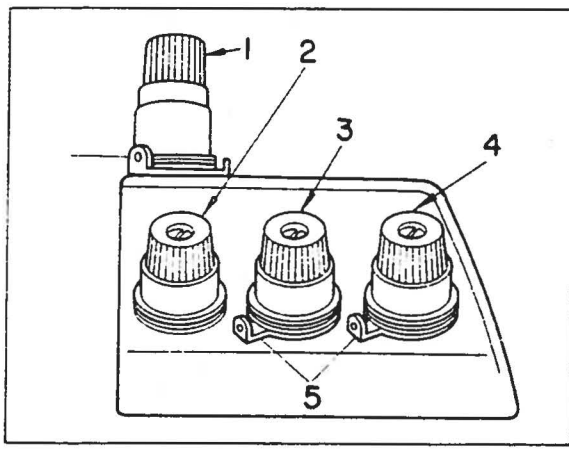
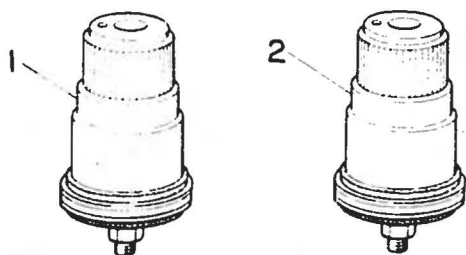

16. MO-806

Ref. No.	Note	Part No.	Description	E.C.	Amt. Req.
	注記	品番		変更年月	数量
1		B3121-704-0B0	Thread tension spring asm.	糸調子バネ結合	1
2		B3102-704-0B0	Thread tension spring asm. (yellow)	糸調子バネ結合 (黄)	2
3		B3103-704-0B0	Thread tension spring asm. (blue)	糸調子バネ結合 (青)	1
4		B3108-704-000	Tension disc thread guide	調子皿糸案内	3

* All other parts are same as gauge sizes of standard subclass machines of MO-814
 この機は同じゲージサイズのMO-814標準サブクラスマシンと同じ

For example: For MO-806-AA4 refer to MO-814-AA4 (例) MO-806-AA4はMO-814-AA4参照
 MO-806-BD4 refer to MO-814-BD4 MO-806-BD4はMO-814-BD4参照
 MO-806-CD4 refer to MO-814-CD4 MO-806-CD4はMO-814-CD4参照

17. MO-807

1	B3121-704-0B0	Thread tension spring asm.	糸調子バネ結合	1
2	B3101-704-0B0	Tension disc thread guide (red)	糸調子バネ結合 (赤)	1
3	B3103-704-0B0	Tension disc thread guide (blue)	糸調子バネ結合 (青)	1
4	B3102-704-0B0	Tension disc thread guide (yellow)	糸調子バネ結合 (黄)	1
5	B3108-704-000	Tension disc thread guide	調子皿糸案内	3

* All other parts are same as gauge sizes of standard subclass machines of MO-814
 この機は同じゲージサイズのMO-814標準サブクラスマシンと同じ

For example: For MO-807-CD4 refer to MO-814-CD4 (例) MO-807-CD4はMO-814-CD4参照
 MO-807-DF6 refer to MO-814-DF6 MO-807-DF6はMO-814-DF6参照

* All parts not mentioned above are same as those of Model MO-814-BD4. 上記以外の部品はMO-814-BD4と共通です

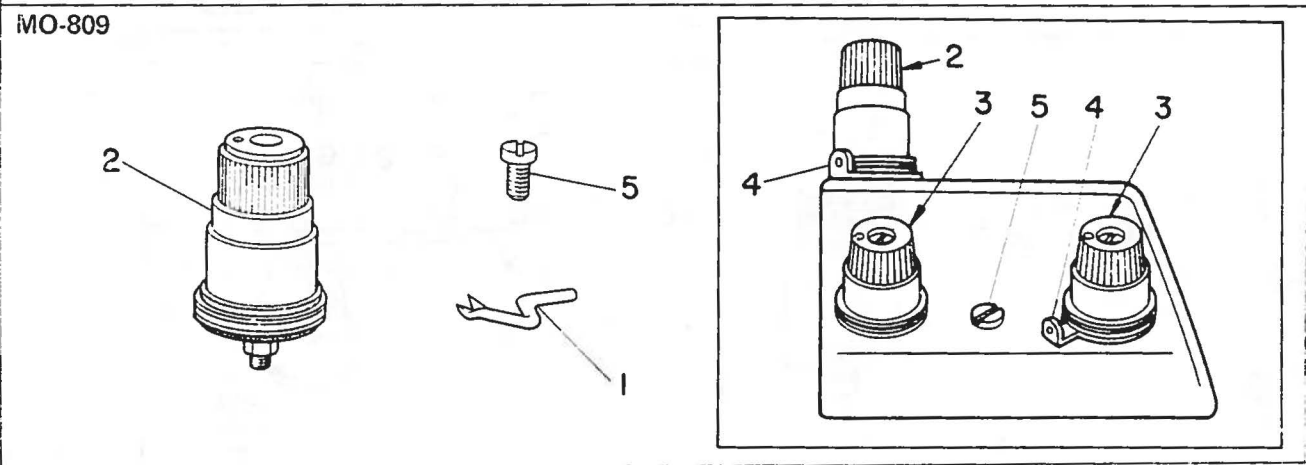
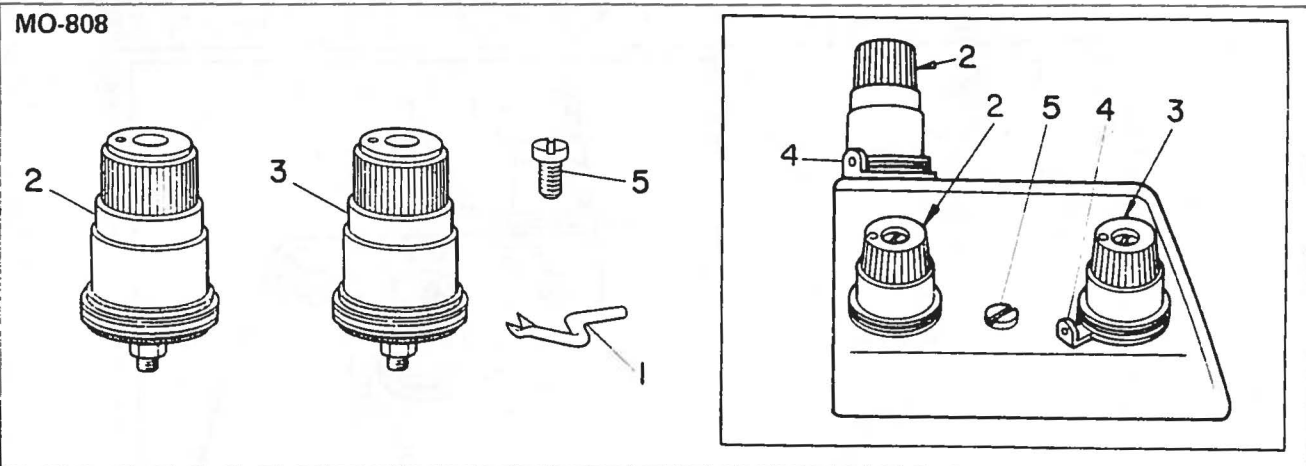

18. MO-808

Part No.	Note	Description	E.C.	Amt. Req.
品番	注記		変更年月	数量
1		Upper blind looper	上カギルーバー	1
2		Thread tension spring asm. (yellow)	糸調子バネ結合 (黄)	2
3		Thread tension spring asm. (blue)	糸調子バネ結合 (青)	1
4		Tension disc thread guide	調子皿糸案内	2
5		Screw	糸調子棒穴蓋ネジ	1

* All other parts are same as gauge sizes of standard subclass machines of MO-814
 この他は同じゲージサイズのMO-814標準 サブクラスマシンと同じ
 For example: For MO-808-CD4 refer to MO-814-CD4 (例)MO-812-CD4はMO-814-CD4参照
 MO-808-CD6 refer to MO-814-CD6 MO-812-CD6はMO-814-CD6参照

19. MO-809

1		Upper blind looper	上カギルーバー	1
2		Thread tension spring asm. (yellow)	糸調子バネ結合 (黄)	2
3		Thread tension spring asm. (blue)	糸調子バネ結合 (青)	1
4		Tension disc thread guide	調子皿糸案内	2
5		Screw	糸調子棒穴蓋ネジ	1

* All other parts are same as gauge sizes of standard subclass machines of MO-814
 この他は同じゲージサイズのMO-814標準 サブクラスマシンと同じ
 For example: For MO-809-BD4 refer to MO-814-BD4 (例)MO-809-BD4はMO-814-BD4参照
 MO-809-CD4 refer to MO-814-CD4 MO-809-CD4はMO-814-CD4参照

* All parts not mentioned above are same as those of Model MO-814-BD4. 上記以外の部品はMO-814-BD4と共通です。

MO-812

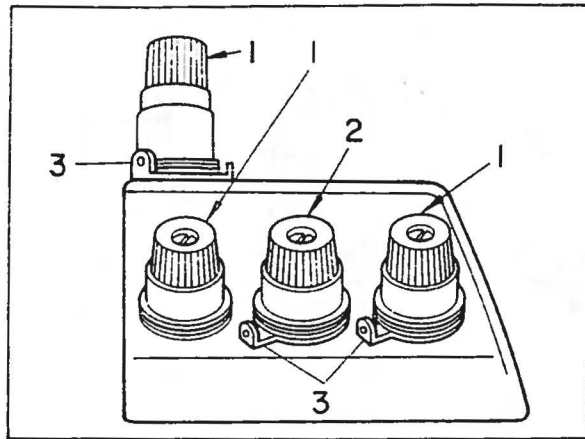

MO-821

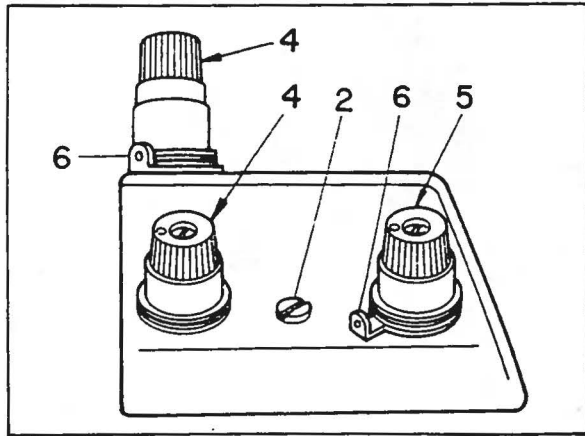
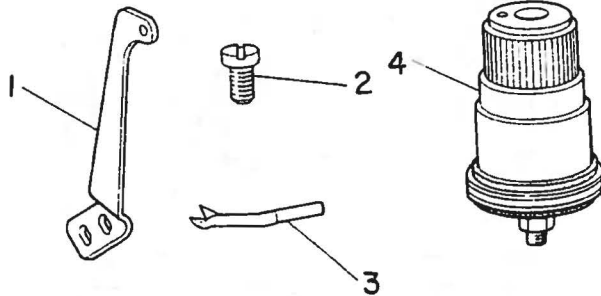

20. MO-812

Ref. No.	Note	Part No.	Description	E.C.	Amt. Req.	
	注記	品番		変更年月	品名	数量
1		B3102-704-0B0	Thread tension spring asm. (yellow)		糸調子バネ結合 (黄)	3
2		B3103-704-0B0	Thread tension spring asm. (blue)		糸調子バネ結合 (青)	1
3		B3108-704-000	Tension disc thread guide		調子皿糸案内	3

* MO-812-DF6 is standard subclass machine. MO-812-DF6は標準サブクラスマシンです。

All others parts are same as gauge sizes of standard subclass machines of MO-814
 この他は同じゲージサイズのMO-814標準 サブクラスマシンと同じ

For example: For MO-812-CD4 refer to MO-814-CD4 [例]MO-812-CD4はMO-814-CD4参照
 MO-812-CD6 refer to MO-814-CD6 MO-812-CD6はMO-814-CD6参照

21. MO-821

1	B1428-803-000	Needle thread take-up lever	針糸天秤	1
2	SS-7110710-SL	Screw	糸調子棒穴蓋ネジ	1
3	B2514-821-000	Upper blind looper	上カギルーバー	1
4	B3103-704-0B0	Thread tension spring asm. (blue)	糸調子バネ結合 (青)	2
5	B3102-704-0B0	Thread tension spring asm. (yellow)	糸調子バネ結合 (黄)	1
6	B3108-704-000	Tension disc thread guide	調子皿糸案内	2

* All other parts are same as gauge sizes of standard subclass machines of MO-814
 この他は同じゲージサイズのMO-814標準 サブクラスマシンと同じ

For example: For MO-821-BD4 refer to MO-814-BD4 [例]MO-821-BD4はMO-814-BD4参照
 MO-821-CD4 refer to MO-814-CD4 MO-821-CD4はMO-814-CD4参照

* All parts not mentioned above are same as those of Model MO-814-BD4. 上記以外の部品はMO-814-BD4と共通です。

22. NUMERICAL INDEX OF PARTS

索引

Part No. 品番	Page 頁	Item Ref. 項目 No.	Part No. 品番	Page 頁	Item Ref. 項目 No.	Part No. 品番	Page 頁	Item Ref. 項目 No.	Part No. 品番	Page 頁	Item Ref. 項目 No.				
EXCLUSIVE PARTS 専用部品			B1507-814-BAG	6	13	1	B2519-804-000	1	1	6	B4121-814-C0A	5	11	8	
B1121-704-000	1	1	12	B1507-814-C0A	4	9	2	B2519-804-000	1	2	6	B4121-814-C0A	6	13	8
B1121-704-000	1	2	12	B1507-814-CAA	4	9	1	B2519-804-000	2	3	6	B4121-814-C0A	6	12	8
B1121-704-000	2	3	12	B1509-814-00B	2	3	3	B2519-804-000	2	4	4	B4121-814-Z0A	1	1	10
B1121-704-000	2	4	10	B1509-814-00B	3	5	3	B2519-804-000	3	5	4	B4121-814-Z0A	1	2	10
B1121-704-000	3	5	10	B1509-814-00B	4	7	3	B2519-804-000	3	5	5	B4121-814-Z0A	2	3	10
B1121-704-000	3	6	9	B1509-814-00C	3	6	2	B3101-704-0B0	8	17	2	R4102-E0A-L00	1	1	9
B1121-704-000	4	7	8	B1509-814-00C	5	10	3	B3102-704-0B0	8	17	4	R4103-E0A-P00	1	2	7
B1419-814-XAD	1	2	4	B1509-814-00C	5	11	3	B3102-704-0B0	8	16	2	R4103-E0B-P00	2	3	7
B1419-814-XAD	2	3	4	B1509-814-00D	1	1	3	B3102-704-0B0	9	18	2	R4204-E0A-B00	2	4	5
B1419-814-ZAE	1	1	4	B1509-814-00D	1	2	3	B3102-704-0B0	9	19	2	R4204-E0C-B00	3	5	7
B1420-712-C0B	6	12	3	B1509-814-00D	2	4	3	B3102-704-0B0	10	20	1	R4204-E0D-B00	3	6	8
B1420-712-C0B	6	13	3	B1511-804-000	4	7	4	B3102-704-0B0	10	21	5	R4205-E0C-C00	4	7	5
B1420-712-D00	7	14	3	B1656-804-00D	1	1	7	B3103-704-0B0	3	16	3	R4206-E0D-E00	4	9	3
B1420-712-D00	7	15	3	B1656-804-00D	1	2	9	B3103-704-0B0	8	17	3	R4305-E0D-E00	5	10	4
B1420-714-A00	2	4	6	B1656-804-00D	2	3	3	B3103-704-0B0	9	18	3	R4306-E0D-E00	5	11	9
B1420-714-A00	3	5	5	B1656-805-000	2	4	8	B3103-704-0B0	9	19	3	R4306-E0E-E00	6	12	4
B1420-714-A00	3	6	3	B1656-805-000	3	5	8	B3103-704-0B0	10	20	2	R4306-E0F-E00	6	13	4
B1420-714-C00	4	9	4	B1656-805-000	3	6	8	B3103-704-0B0	10	21	4	R4308-E0D-E00	7	14	4
B1420-714-C00	5	11	4	B1656-805-000	4	7	6	B3108-704-000	8	16	4	R4308-E0F-E00	7	15	4
B1428-803-000	10	21	1	B1656-812-D0C	6	13	5	B3108-704-000	8	17	5	NEEDLE			
B1507-812-D0C	7	15	2	B1656-812-D0C	6	12	5	B3108-704-000	9	19	4	MDC-C46B0900	1	1	5
B1507-812-D0C	7	14	2	B1656-812-D0C	7	14	5	B3108-704-000	9	18	4	MDC-C46B0900	2	4	7
B1507-812-DAC	7	15	1	B1656-812-D0C	7	15	5	B3108-704-000	10	20	3	MDC-C46B0900	3	5	6
B1507-812-DAC	7	14	1	B1656-814-B0A	5	10	5	B3108-704-000	10	21	6	MDC-C46B0900	3	6	4
B1507-814-00C	1	1	2	B1656-814-B0A	5	11	5	B3121-704-0B0	8	16	1	MDC-C47B0900	1	2	5
B1507-814-00C	1	2	2	B1657-804-00E	1	1	8	B3121-704-0B0	8	17	1	MDC-C47B0900	2	3	5
B1507-814-00C	2	3	2	B1657-804-00E	1	2	8	B4118-804-000	1	1	13	SCREW			
B1507-814-00C	2	4	2	B1657-804-00E	2	3	9	B4118-804-000	1	2	13	SS-7110710-SL	9	18	5
B1507-814-00C	3	5	2	B1657-805-000-A	2	4	9	B4118-804-000	2	3	13	SS-7110710-SL	9	19	5
B1507-814-00C	4	7	2	B1657-805-000-A	4	7	7	B4118-804-000	2	4	11	SS-7110710-SL	9	19	5
B1507-814-00D	5	10	2	B1657-805-000-A	3	6	7	B4118-804-000	3	5	11	SS-7110710-SL	10	21	2
B1507-814-00D	5	11	2	B1657-812-D0A	6	12	7	B4118-804-000	4	7	9				
B1507-814-00G	6	13	2	B1657-812-D0A	7	14	7	B4120-812-00H	7	15	9				
B1507-814-00G	6	12	2	B1657-812-D0A	7	15	7	B4120-812-00H	7	14	9				
B1507-814-0AC	2	3	1	B1657-812-D0A	6	13	7	B4120-814-C0A	4	9	6				
B1507-814-0AC	3	5	1	B1657-814-B0A	5	10	6	B4120-814-C0A	5	11	7				
B1507-814-0AC	4	7	1	B1657-814-B0A	5	11	6	B4120-814-C0A	6	12	9				
B1507-814-0AD	5	10	1	B1658-812-00A	6	12	6	B4120-814-C0A	6	13	9				
B1507-814-0AD	5	11	1	B1658-812-00A	6	13	6	B4120-814-Z0A	1	1	11				
B1507-814-0AE	3	6	1	B1658-812-00A	7	14	6	B4120-814-Z0A	1	2	11				
B1507-814-0AF	1	1	1	B1658-812-00A	7	15	6	B4120-814-Z0A	2	3	11				
B1507-814-0AF	1	2	1	B2514-803-000	9	18	1	B4121-812-C0J	7	14	8				
B1507-814-0AF	2	4	1	B2514-821-000	9	19	1	B4121-812-C0J	7	15	8				
B1507-814-BAG	6	12	1	B2514-821-000	10	21	3	B4121-814-C0A	4	9	5				

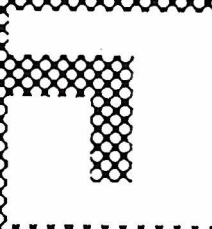

JUKI®

TOKYO JUKI INDUSTRIAL CO., LTD.

Address : 23-3, Kabuki-cho 1-chome, Shinjuku-ku,
Tokyo 160, Japan

Cable : JUKI TOKYO

Telex : 22967, 232-2301

Phone : 03 (205) 1188, 1189, 1190



東京重機工業株式会社

〒162

東京都新宿区神楽坂1丁目23番3号 TEL 480 1111 (大阪)